



www.johnsonhardware.com

INSTRUCTIONS

2222 Series SLIDING DOOR HARDWARE

For 1 3/8" Doors
Up to 50 lbs.
(single wheel hanger)
Up to 75 lbs.
(double wheel hanger)

OPENING SIZES

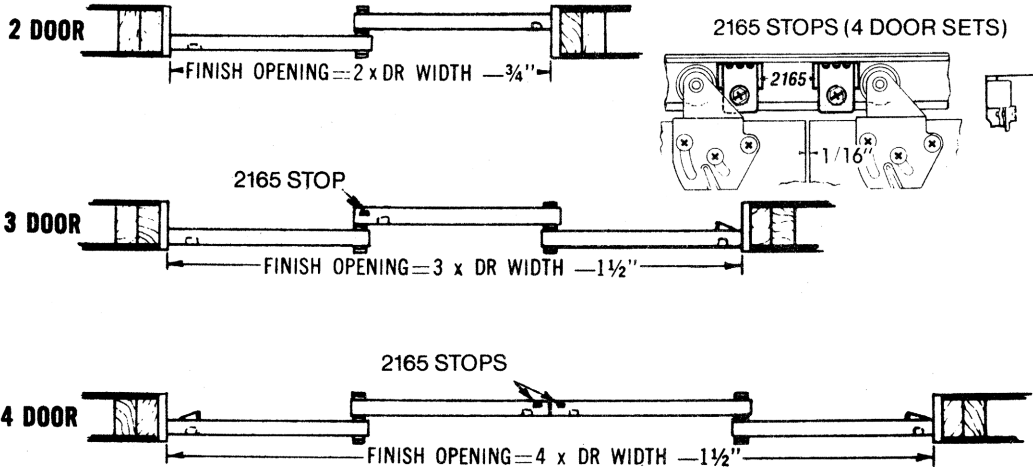

PREPARE OPENING

Make sure rough opening is square and straight. Stated dimensions allow for shimming of finished jamb. Place header ends into dado of side jambs and nail in place. Place assembled frame into rough opening and shim in place, being certain that **FRONT** edge is on room side (See diagram). Fasten track to rough header with screw through hole in center of track. Do not overtighten.

Opening may be finished with trim at this time.

DOORS

Finish doors **ON ALL SURFACES** before mounting hangers. This seals against moisture which causes warping. Fasten hangers on **BACK** side of doors, 1" from each edge. Temporarily raise hangers to highest position for easier hanging. (Screws must be placed at top end of slots when hanger is in the lowest position.)

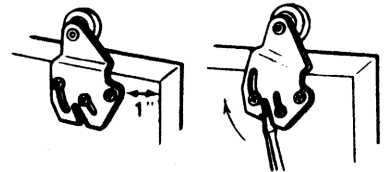

Holes for pulls may be drilled at this time, or after doors are hung. Holes must be large enough to avoid splitting, but snug enough to hold pull in place. (If holes are too large, wrap tape around pull.)

Hang back door first. Tilt top of door back and place both hangers on rear rail of track. Let hang free. Repeat with front door on front rail.

Adjust hangers to raise doors as high as possible, keeping door edges square with side jambs.

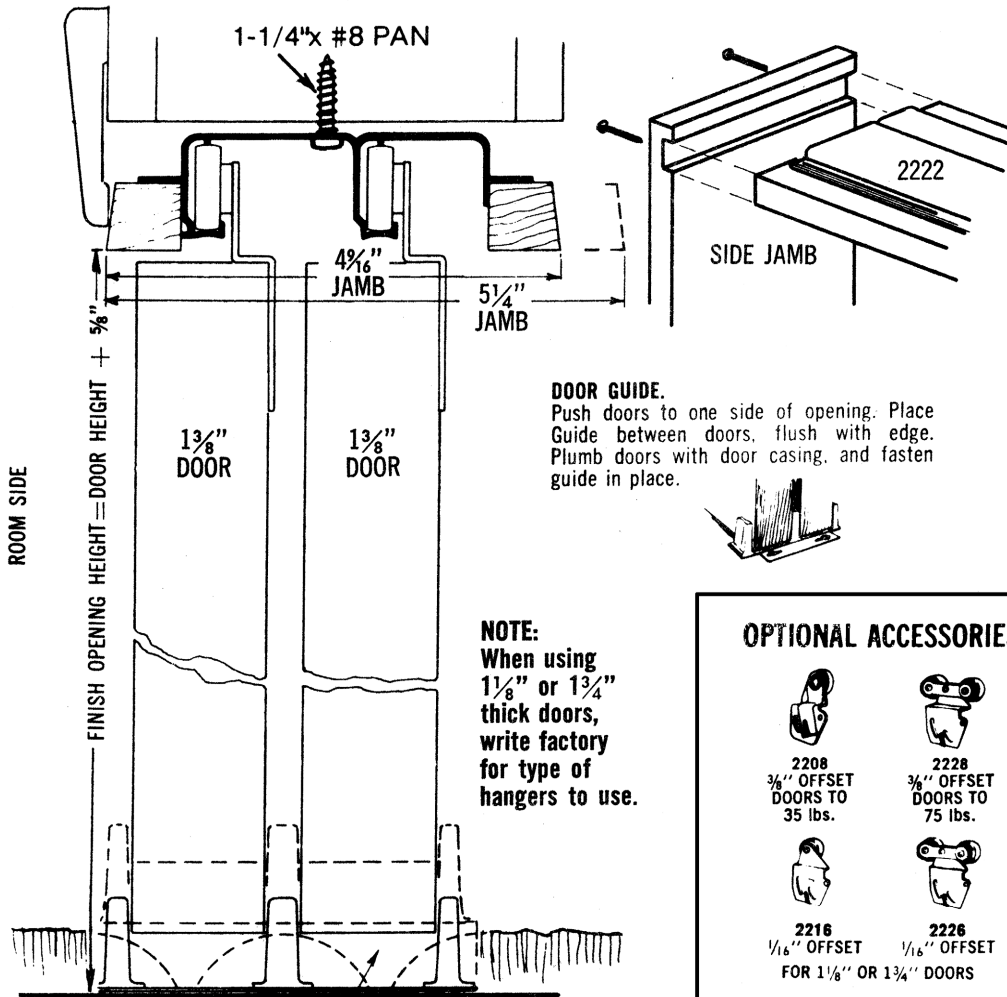
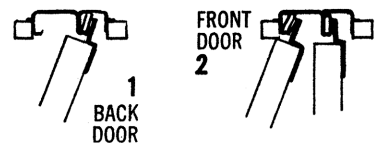

DOOR GUIDE.

Push doors to one side of opening. Place Guide between doors, flush with edge. Plumb doors with door casing, and fasten guide in place.

NOTE:
When using 1 1/8" or 1 3/4" thick doors, write factory for type of hangers to use.

OPTIONAL CARPET RISER — 2136
(If carpet riser is used, cut 5/8" from door bottoms)

OPTIONAL ACCESSORIES

Pulls are available in three finishes

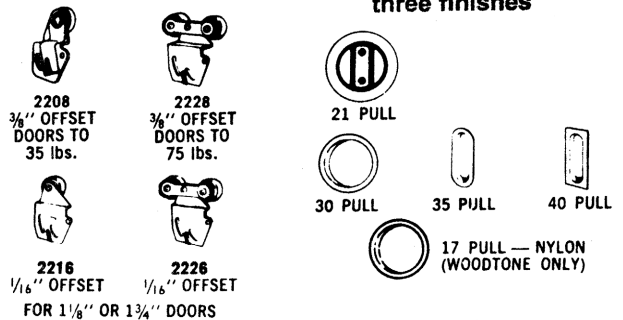

L.E. JOHNSON PRODUCTS, INC. • 2100 STERLING AVE.

• ELKHART, IN 46516 • 574-293-5664

IN222SD Rev. 1/02